



Hyperspike
Series

solidsteel

HF

Series

Dear Music Lover,
welcome to the discovery of
the Hyperspike Series, our top range
products designed and created
to satisfy the most prestigious needs.

It is a technical series.

The elegant aesthetic merge with
the functional choices to better
valorize the audio and video
components.

In this Series there are harmonies and
geometrical relationships.

Chromatic contrasts between surfaces
and our love for what we do.

We are at music's service
and nothing else.

Let your imagination work,
the Hyperspike Series is born to
deserve your experiences.

All the selected materials are
of excellent quality and of Italian
origin, worked with the maximum
care and passion that distinguishes
us from the very beginning.



The structural concept of the Hyperspike Series is functional, simple in design and effective. It consists of an MDF Light shelf (a specific type of Medium Density Fibreboard, mechanically and acoustically very solid), finished by a strong modern-looking glass finish (available in black or white) or by an elegant flat black varnish. Each type of finish is made to damp component's vibrations and has non-scratch properties. The shelves consists of a quadrangular shape, noticeably rounded without corners forming a smooth, graceful profile that gives continuity to its aesthetic and practical features. Each shelf is 30mm thick, 550mm deep at its maximum point (front to back) and 650mm wide; capable of accommodating most audio and A/V components including High-End products, which often cannot be suited by the industry standard 19-inch component size. Each Hyperspike product can support 70 Kg (tested) for shelf.

solidsteel

The HF Series is characterized by a four pillar structure. A massive rack that expresses our higher technology and experience.

HS

Series

The three pillar design is geometrically positioned to give maximum support and minimum physical contact with the surrounding environment. The rack stems are made of high quality solid steel rods, polished by a state of the art process giving a smooth and shimmering finish. In order to provide the necessary modular structure, the frames comprise a central segment of variable length to meet diverse requirements, to which are attached the other elements that make up the rest of the support mechanism. Adding to the technical composition are securing screws, insulating spikes (very strong, beautifully secured, adjustable, strong locking with a clamping screw) and decoupling pads, also made of solid steel. Amongst the elements to be assembled are rubber o-rings, similar to a piston ring with the purpose of improving the fit while reducing the transmission of mechanical energy. This is the Hyperspike Vibration Free System, designed by Solidsteel.

The Hyperspike Series is the only range out of the Solidsteel catalogue of products capable of being stacked, with modular kits available that can be assembled according to the client's need. The Hyperspike Series offers a multitude of solutions thanks to its upgrade kits.

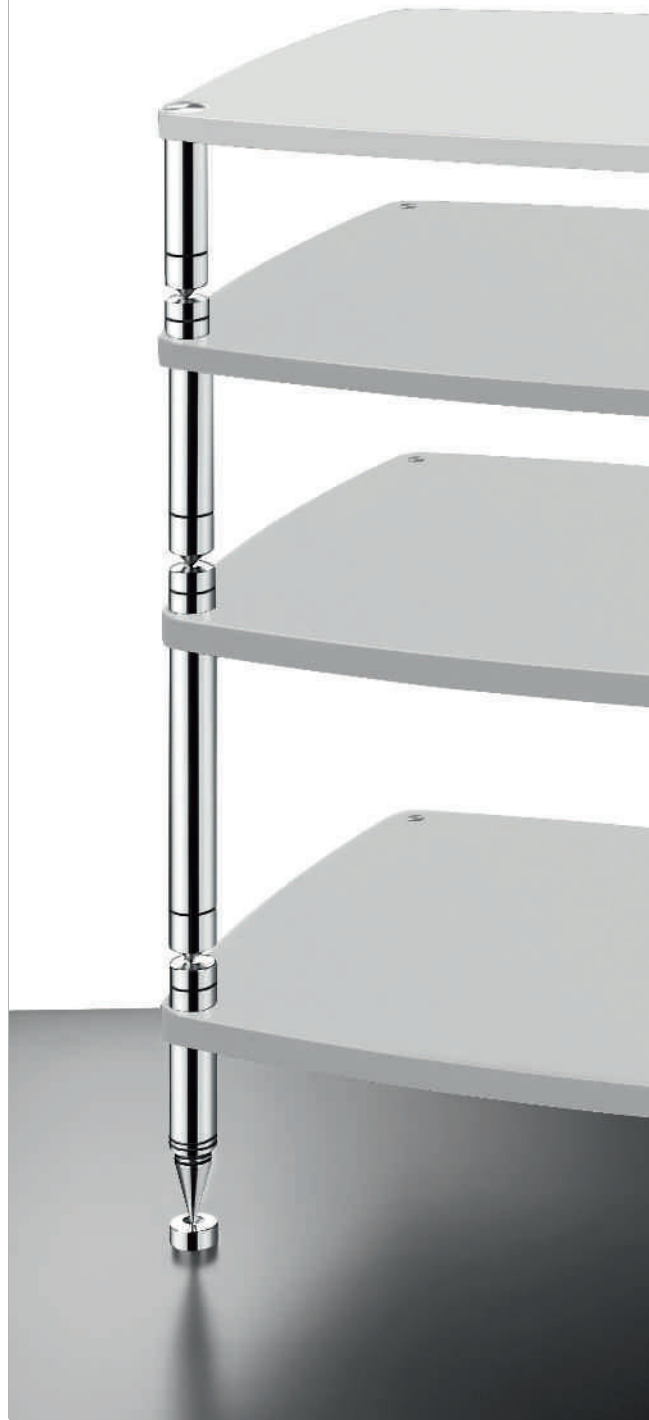

HF

2

Two shelves modular audio table, solid stainless steel quadruped design. It's well suited for minimalist, high performances systems (source + amp). Perfect if coupled to place with elegance more components in the same room.

Three finishes available: Flat Black, Glossy Black and Glossy White.



Glossy White

HF

3

Three shelves modular audio table, solid stainless steel quadruped design. It's well suited for essential, high performances systems (source + pre & power-amp; or turntable, digital player and integrated amp). Perfect if coupled to place with elegance more components in the same room.

Three finishes available: Flat Black, Glossy Black and Glossy White.



Glossy Black

HS

2

Two shelves modular audio table, solid stainless steel tripod design makes for ease of leveling. It's well suited for minimalist, high performances systems (source + amp). Perfect if coupled to place with elegance more components in the same room.

Three finishes available: Flat Black, Glossy Black and Glossy White.

Glossy White



HS

3

Three shelves modular audio table, solid stainless steel tripod design makes for ease of leveling. It's well suited for essential, high performances systems (source + pre & power-amp; or turntable + digital player & integrated amp). Perfect if coupled to place with elegance more components in the same room.

Three finishes available: Flat Black, Glossy Black and Glossy White.

Glossy Black



HF

4

Four shelves modular audio rack with a solid steel quadruped design.

It's perfect for any kind of need and allows to suite sophisticated, high quality systems.

We recommend to consider the bottom shelf for the power-amp and the upper levels for the pre-amp, digital player and turntable.

Three finishes available:
Flat Black, Glossy Black and
Glossy White.

Glossy White



HS

4

Four shelves modular audio table with a solid steel tripo design.

It is well suited for sophisticated, high quality systems (analogue turntable, digital player, amp).

We recommend to place the eventual huge power-amp always on the bottom shelf for the best load distribution.

Three finishes available: Flat Black, Glossy Black and Glossy White.

Flat Black



Glossy Black

HF HS

A&B



HS-B in Glossy White

The HF-A (and HF-B) are four-legs audio bases, special made for audio power-amps. 600mm in depth for the A makes it the perfect solution for the biggest of power units. 480mm in depth for the B makes it the ideal solution for the standard sized power units on the market.

Three finishes available: Flat Black, Glossy Black and Glossy White.



HF-A in Flat Black

The HS-A (and HS-B) are three-legs audio bases, special made for audio power-amps. 600mm in depth for the A makes it the perfect solution for the biggest of power units. 480mm in depth for the B makes it the ideal solution for the standard sized power units on the market.

Three finishes available: Flat Black, Glossy Black and Glossy White.



HS-A in Glossy Black

HJ

Series

If the aim of the Hyperspike Series is to achieve new goals in performance, excellence in workmanship materials used while offering solutions to audio system designs, then the very latest Hyperspike Junior combines this distinction with convenience, thanks to a well thought out cost control analysis that makes possible to keep the overall performance at a very high level yet.



The Hyperspike Junior Series incorporates the main mechanical characteristics and materials of the “no compromise” reference level Hyperspike range but at a fraction of the cost. The pillars are made of solid, polished steel and the shelves from 30mm thick MDF Light. The containment in costs for the HJ Series has been achieved by simplifying some elements. The shelves are of a simpler design, with parallel sides making it easier and less costly to manufacture. The decoupling spikes though without o-rings, remains threaded and adjustable. Finally, the finishing of the shelves, available only in embossed black, is very functional and aesthetically neutral. The Solidsteel Hyperspike Junior Series isolation rack was designed to provide reference level support for your audio system without the price tag.

HJ

2

Two-shelf modular audio table with a solid steel, tripod design. It is ideal for the minimal needs, perfect if coupled to suite more components. Available only in Flat Black finish.



HJ

3

Three-shelf modular audio table with a solid steel, tripod design. It is ideal for the basilar needs, perfect if coupled to suite more components. Available only in Flat Black finish.



HJ

4

Four-shelf modular audio
table with a solid steel,
tripod design.
It is ideal for the any need.

Available only in Flat Black
finish.



HJ

A

HJ-A & HJ-B audio tables are the ideal HJ Series integration. HJ-A is a 60 cm deep size shelf with 3 solid steel legs and a 30 mm MDF shelf, well suited for extra-large size power-amps. HJ-B is made for standard 48cm size power-amps.

Audio Base specially made for power amps, in a solid steel, tripo design. Available only in Flat Black finish.



HJ

B

Flat Black



HW Series

There are four models in the range: HW-2 and HW-3, designed for 42" TV screens while HW-2L and HW-3L are suitable for 50" TV screens.

The Hyperspike Junior Series is also aimed at users of audio-video components who want to achieve the best performance possible with their system. The Hyperspike Wide Series was created, with structures capable of accommodating and supporting a wide-screen TV together with other components such as a DVD player, AV amplifier, central speaker and decoder. The Hyperspike Wide models come in a five-fixed pillar structure for maximum support with adjustable flat foot ends for maximum ease of positioning. Three finishes are available: Flat Black, Glossy Black and Glossy White.

Glossy White



HW 2

Two-shelf audio table,
with solid steel, five pillar
structure. MDF Light
shelves. Solid steel
adjustable feet.

Glossy Black

Glossy White

Flat Black



HW 2L

Two-shelf audio table,
with solid steel, five pillar
structure. MDF Light
shelves. Solid steel
adjustable feet.

Glossy White

Flat Black

Glossy Black



HW 3

Three-shelf audio table,
with solid steel, five pillar
structure. MDF Light
shelves. Solid steel
adjustable feet.

Flat Black



Glossy Black



Glossy White



HW 3L

Three-shelf audio table,
with solid steel, five pillar
structure. MDF Light
shelves. Solid steel
adjustable feet.

Flat Black



Glossy Black

Glossy White



HF HS

The Hyperspikes HF&HS Series predefined solutions make it possible to obtain ready assembled and functional models for most uses, but it is also possible to assemble the support structure according to one's particular needs by viewing the many flexible variations found in the catalogue.

Kit

Custom made solutions: for a personalised structure, the first step is the Starter-Kit. The Starter-Kit consists only of legs, spikes and discs. One must add the shelf, which can be purchased separately. The clearance between the shelves vary between 165mm and 305mm, at 20cm increments. This solution accommodates a minimalist system consisting of a source and an integrated amplifier. With the expansion of the music system, it is also possible to enlarge the structure that supports it. It needs the simple addition of one or more Add-Kits, between 145mm and 265mm in height between the two existing shelves. The finish of the shelves is available in black rubberised varnish, white lacquer, black lacquer.

HFS Starter-Kit

- ① 3 or 4 discs
- ② 3 or 4 adjustable termination legs height 175 mm
- ③ 3 or 4 pads with o-ring
- ④ 3 or 4 optional legs in eight size variants* from 165 to 305 mm
- ⑤ 3 or 4 upper terminations

*optional legs size

165 mm
185 mm
205 mm
225 mm
245 mm
265 mm
285 mm
305 mm

HFS Add-Kit

- ④ 3 or 4 optional legs in seven size variants* from 145 to 265 mm
- ③ 3 or 4 pads with o-ring

*optional legs size

145 mm
165 mm
185 mm
205 mm
225 mm
245 mm
265 mm



Starter-Kit HFS Series - Hyperspikes

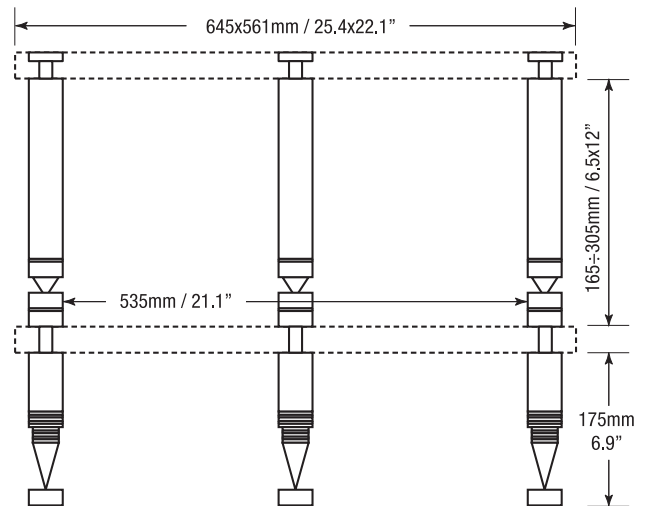

Add-Kit HFS Series - Hyperspikes

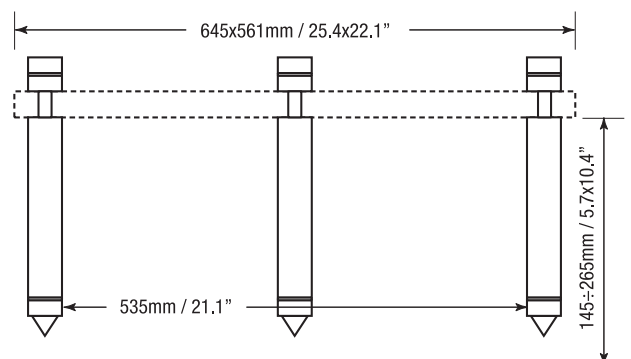

HJ

Kit

The Hyperspike HJ Series predefined solutions make it possible to obtain ready assembled and functional models for most uses, but it is also possible to assemble the support structure according to one's particular needs by viewing the many flexible variations found in the catalogue.

Custom made solutions: for a personalised structure, the first step is the Starter-Kit. The Starter-Kit consists only of legs, spikes and discs. One must add the shelf, which can be purchased separately. The clearance between the shelves vary between 165mm and 305mm, at 20cm increments. This solution accommodates a minimalist system consisting of a source and an integrated amplifier. With the expansion of the music system, it is also possible to enlarge the structure that supports it. It needs the simple addition of one or more Add-Kits, between 145mm and 265mm in height between the two existing shelves. The finish of the shelves is only available in matt black.

HJ Starter-Kit

- ① 3 discs
- ② 3 adjustable termination
- ③ 3 pads
- ④ 3 optional legs in eight size variants* from 165 to 305 mm
- ⑤ 3 upper terminations

*optional legs size

- 165 mm
- 185 mm
- 205 mm
- 225 mm
- 245 mm
- 265 mm
- 285 mm
- 305 mm

HJ Add-Kit

- ④ 3 optional legs in seven size variants* from 145 to 265 mm
- ③ 3 pads with o-ring

*optional legs size

- 145 mm
- 165 mm
- 185 mm
- 205 mm
- 225 mm
- 245 mm
- 265 mm



Starter-Kit HJ Series - Hyperspike Junior

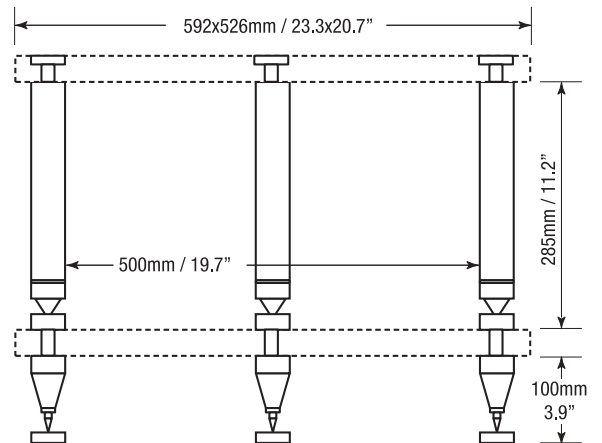

Add-Kit HJ Series - Hyperspike Junior

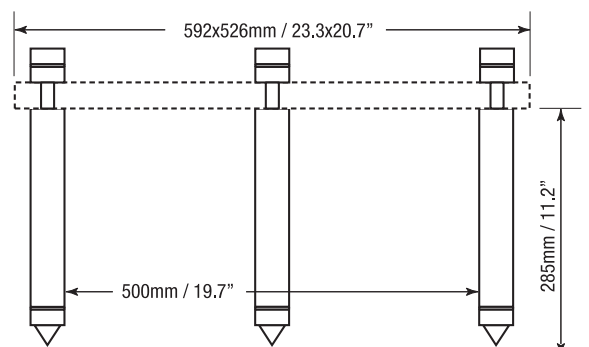

HF HS

Dimensions

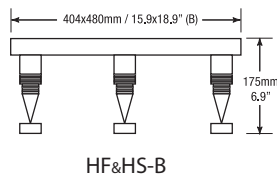
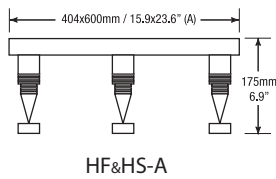
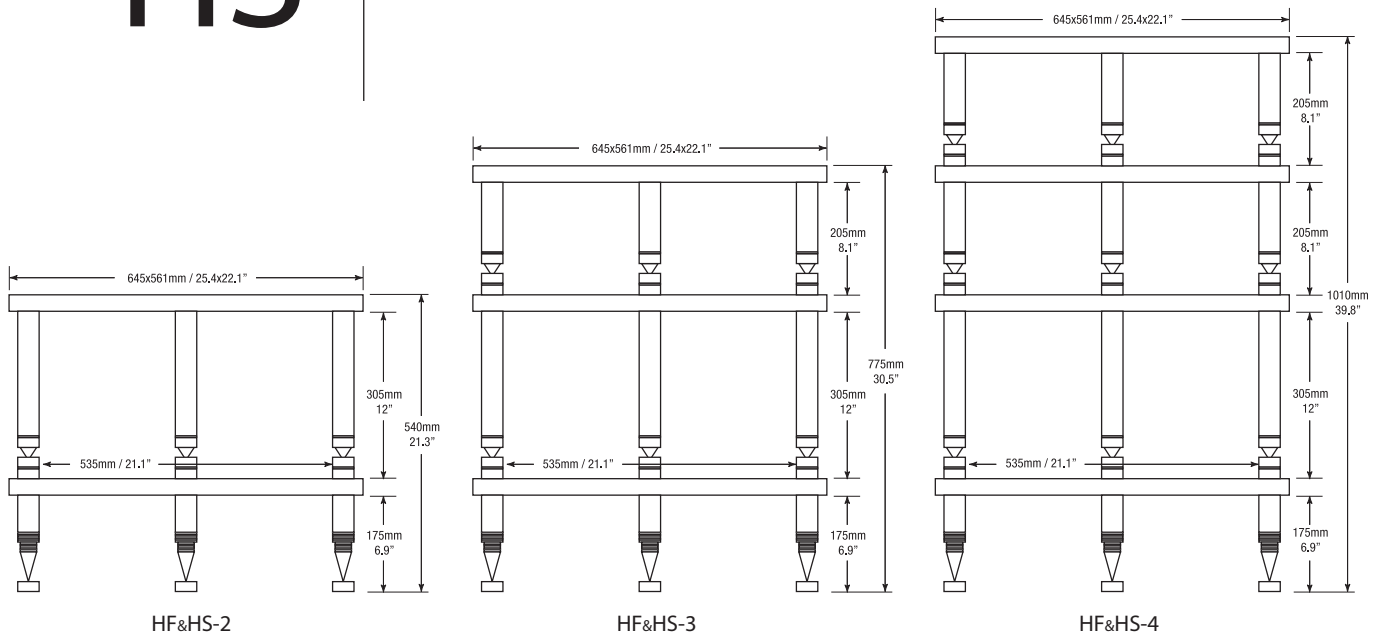

The HF Series dimensions are the same of the ones showed above, exception made, obviously, for the frame configuration, which is based on 4 poles instead of the 3.

Model	Features	Outer Dimensions	Inner Shelves Dimensions	Color Finishing
HF&HS-2	Two-shelf audio table	L645 H540 P561	L535 H305 P500	Flat Black - Glossy White - Glossy Black
HF&HS-3	Three-shelf audio table	L645 H775 P561	L535 H305-205 P500	Flat Black - Glossy White - Glossy Black
HF&HS-4	Four-shelf audio table	L645 H1010 P561	L535 H305-205-205 P500	Flat Black - Glossy White - Glossy Black
HJ-2	Two-shelf audio table	L592 H445 P526	L500 H285 P480	Flat Black
HJ-3	Three-shelf audio table	L592 H660 P526	L500 H285-185 P480	Flat Black
HJ-4	Four-shelf audio table	L592 H875 P526	L500 H285-185-185 P480	Flat Black

Audio/Video - Audio Tables

HW-2	Two-shelf audio table	L1090 H386 P410	L1000 H244 P365	Flat Black - Glossy White - Glossy Black
HW-3	Three-shelf audio table	L1090 H620 P410	L1000 H224-224 P365	Flat Black - Glossy White - Glossy Black
HW-2L	Two-shelf audio table	L1280 H386 P410	L1186 H244 P365	Flat Black - Glossy White - Glossy Black
HW-3L	Three-shelf audio table	L1280 H620 P410	L1186 H224-224 P365	Flat Black - Glossy White - Glossy Black

Audio Table for Power-Amps

HF&HS-A	Audio table for power-amps	L404 H175 P600	L404 x P600	Flat Black - Glossy White - Glossy Black
HF&HS-B	Audio table for power-amps	L404 H175 P480	L404 x P480	Flat Black - Glossy White - Glossy Black
HJ-A	Audio table for power-amps	L404 H130 P600	L404 x P600	Flat Black
HJ-B	Audio table for power-amps	L404 H130 P480	L404 x P480	Flat Black

HJ

Dimensions

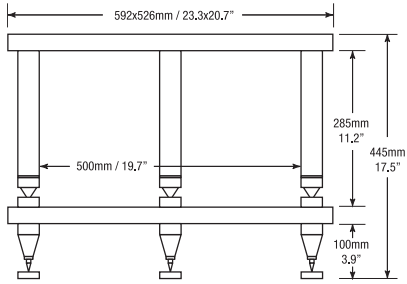

HJ-2

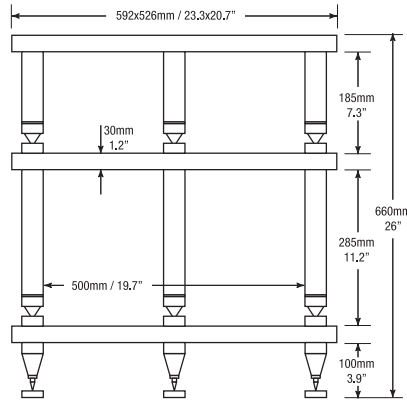

HJ-3

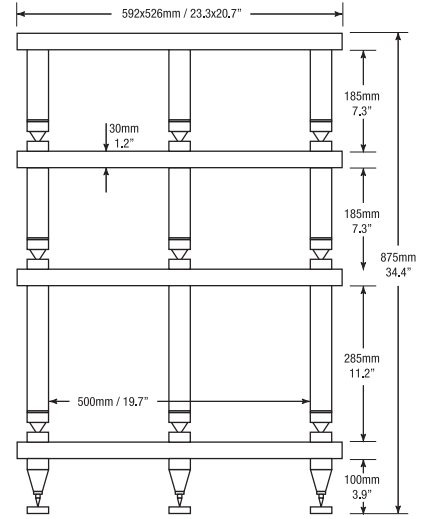

HJ-4

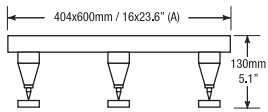

HJ-A

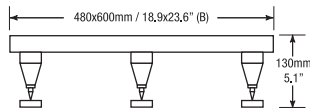

HJ-B

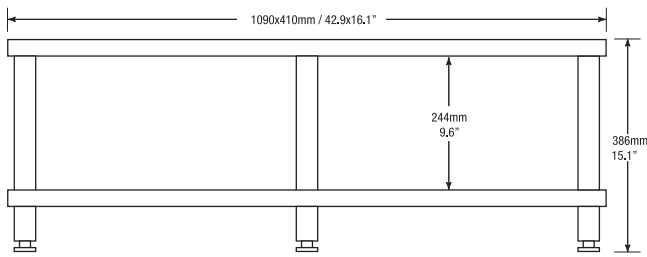

HW-2

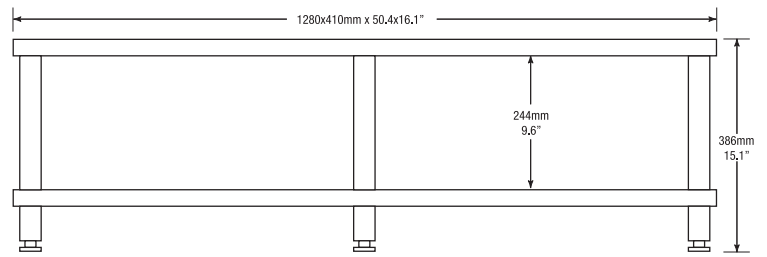

HW-2L

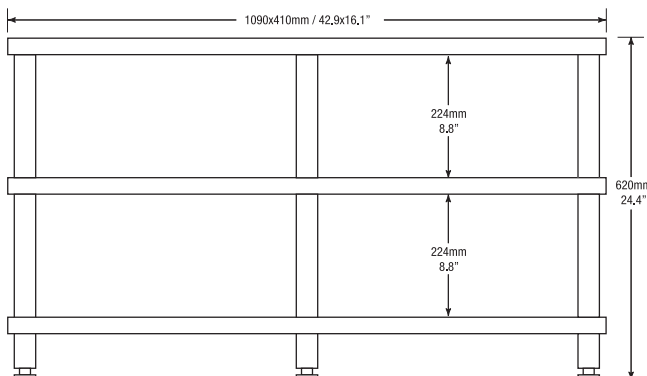

HW-3

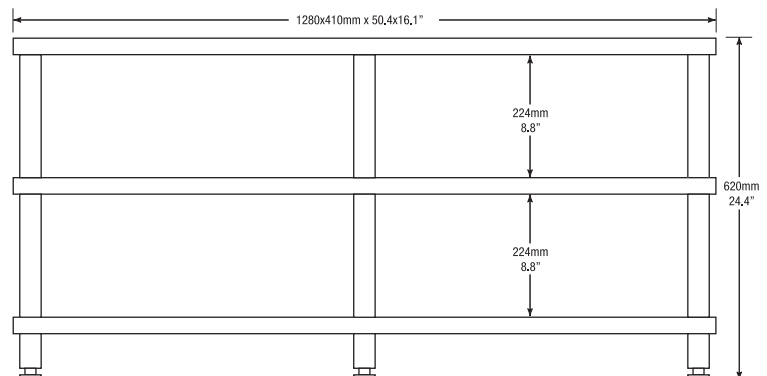

HW-3L

solidsteel

www.solidsteel.it

MADE IN ITALY SINCE 1990

